



Hybrid Flex Inverter System

48,000 BTU 8-Zone Mix & Match Flexibility

Mini-Split Air Conditioners and Heat Pumps



Wall Mounted



Slim Duct



Compact Cassette

For over 35 years, Fujitsu has been making the hottest places cool and the coolest places more comfortable.



What is a Hybrid?

The blending of a complex VRF system with the simplicity of a multi-zone system to create a new hybrid solution that shares the best of both systems.

Why Flex?

The ability to create the right combinations, the right quantity (up to 8-zones), the right style indoor units, and the right capacity. It's the right choice for your home or business.

Why Inverter?

An Inverter is a system that controls the rotational speed (not just an ON/OFF signal) of an electric motor by adjusting the frequency and voltage of the electrical power supplied to the motor. The inverter constantly regulates the compressor speed to its optimum energy usage, producing higher refrigerant performance with less power consumption.

130% Connectable Capacity (Halcyon Hybrid Flex Inverter (HFI) System Only)

The HFI system is rated at 48,000 BTUs but you can connect up to 130%, or 62,000 BTUs of rated evaporator capacity to the AOU48RLXFZ. All indoor units can operate at once, however if all the evaporators are calling for cooling or heating at the same time it will decrease the capacity of each evaporator not to exceed the condenser's capacity. As zones meet desired set point the system's other evaporators increase output up to the evaporator's rated capacity.

For example: The load on a small 2-story office building with a business downstairs and worker apartments upstairs is 62,000 BTUs (38,000 BTUs downstairs and 24,000 BTUs upstairs) but the workers aren't upstairs and downstairs at the same time, therefore not all units will be running simultaneously allowing 100% heating or cooling to occupied spaces.

HFI vs. Multi vs. VRF

AHRI defines VRF as having three main features: (1) a variable speed compressor, (2) a computerized control individual zoning system and (3) optimized refrigerant path of installation.

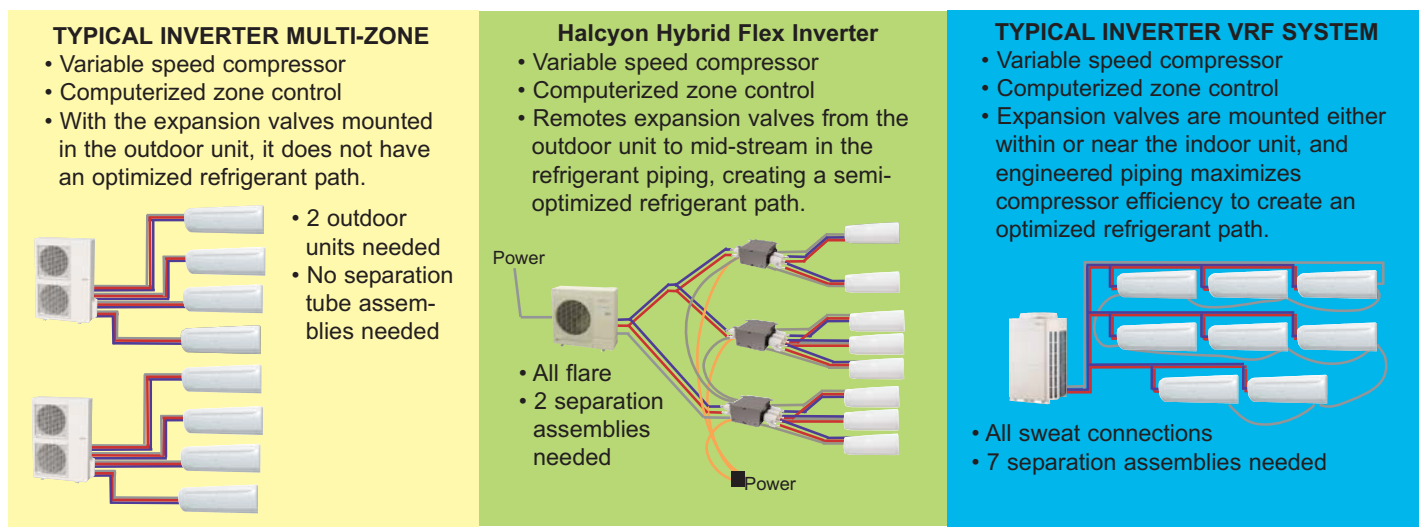
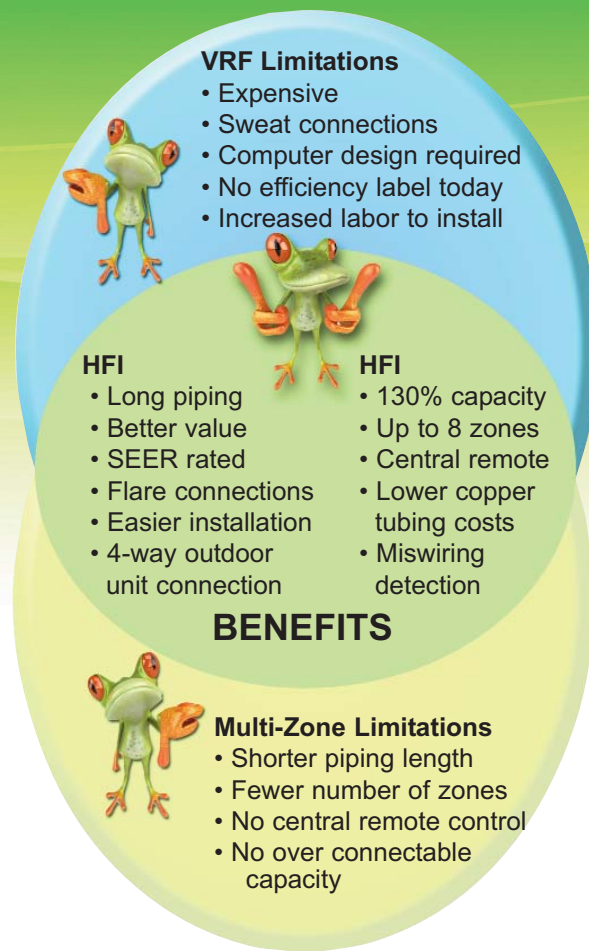

Outdoor Unit 48,000 BTUs

AOU48RLXFZ



- Connect 2 to 8 indoor units
- 80 to 130% connectable capacity
- Connect 39,000 to 62,000 BTU

2 Indoor Units

18k BTU/h + 24 k BTU/h = 42k BTU/h ··OK
 12k BTU/h + 24 k BTU/h = 36k BTU/h ··Not Allowed (below 80%)

8 Indoor Units

7k BTU/h × 8 units = 56k BTU ··OK
 9k BTU/h × 8 units = 72k BTU ··Not Allowed (over 130%)

Compact Size

The compact size of outdoor unit AOU48RLXFZ allows for many installation opportunities.

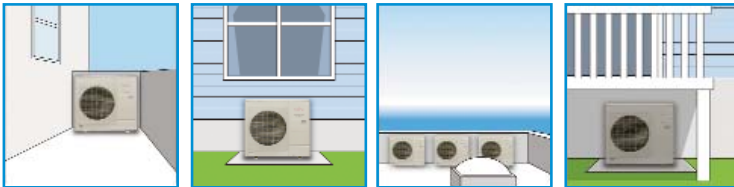

Self Diagnostic Feature

This printed circuit board provides three modes of diagnostics - setting, monitoring and function mode, as well as error codes. It also provides a pre-commissioning check function. Setting mode allows optional functions to be selected. Monitoring mode provides temperature for each thermistor, compressor operation and other functions. Function mode provides cooling test run, heating test run and pump down operation.



Piping Flexibility

Contractors can choose the best direction for piping from the outdoor unit.

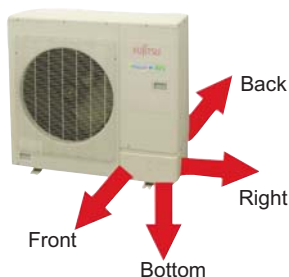

DC Twin Rotary Compressor

A high performance, low noise, large capacity DC twin rotary compressor is used. Includes Quiet Mode for night operation.



AOU48RLXFZ Heat Pump

Connectable Indoor Unit Number	2 to 8
Connectable Indoor Unit Capacity	80 to 130% Nominal (39,000 - 62,000 BTU)
Connectable Branch Box Number	1 to 3
Nominal Cooling BTU/h	48,000
Max Cooling BTU/h	51,100
Nominal Heating BTU/h	54,000
Low Temp. Heating 17°F BTU/h	40,000
Max Heating BTU/h	57,000
Clg. Operating Range °F(°C)	25-115 (-5-46)
Htg. Operating Range °F(°C)	5-75 (-15-24)
Input Power: Cooling Rated kW*	5.52 / 5.19 / 5.35
Input Power: Heating Rated kW*	22.3 / 21.7 / 22.0
Voltage/Frequency/Phase	208-230/60/1
Current: Clg Outdoor Max. (A)	24.5 / 23.0 / 23.7
Current: Htg Outdoor Max. (A)	22.3 / 21.7 / 22.0
Recommended Fuse Size (A)	40
Outdoor Fan Speed RPM (Clg/Htg)	890/910
Fan: Type x Quantity	Propeller x 1
Fan Motor Output W	111
Sound Pressure Level Cooling dB(A)	56
Sound Pressure Level Heating dB(A)	58
Max. Pipe Length Total Ft (m)	377 (115)
Max. Pipe Length Between Box & Farthest Indoor Unit Ft (m)	49 (15)
Max. Pipe Height Difference Between Outdoor Unit & Branch Box Ft (m)	98 (30)
Max. Pipe Height Difference Between Indoor Units Ft (m)	98 (30)
Max. Pipe Height Difference Between Outdoor Unit & Farthest Indoor Ft (m)	98 (30)
Connection Method	Flare
Conn. Pipe Diameter Inch	3/8 (Liq.) 5/8 (Suc.)
Net Weight lbs. (kg)	216 (98)
Dimensions: Height Inch	36
mm	914
Width Inch	38-1/4
mm	970
Depth Inch	14-5/8
mm	370
Refrigerant	R410A

*Ducted / Non-Ducted / Mixed

	SEER	HSPF	EER**
Ducted	14.7	9.3	8.7
Non-Ducted	17.0	9.8	9.25
Mixed	15.8	9.5	8.97

**Cooling



Wall Mounted 7, 9, 12, 18 and 24,000 BTUs

ASU7RLF, ASU9RLF, ASU12RLF, ASU18RLF, ASU24RLF



ASU7, 9, 12RLF



ASU18, 24RLF

	ASU7RLF	ASU9RLF	ASU12RLF	ASU18RLF	ASU24RLF
	Heat Pump	Heat Pump	Heat Pump	Heat Pump	Heat Pump
Nominal Cooling BTU/h	7,000	9,000	12,000	18,000	24,000
Nominal Heating BTU/h	8,100	10,200	13,500	20,000	27,000
Voltage/Frequency/Phase	208-230/60/1	208-230/60/1	208-230/60/1	208-230/60/1	208-230/60/1
Air Circ. C.F.M. (m ³ /h): Hi	330 (560)	353 (600)	388 (660)	542 (920)	647 (1,100)
Medium	294 (500)	306 (520)	330 (560)	436 (740)	530 (900)
Low	253 (430)	253 (430)	265 (450)	365 (620)	436 (740)
Quiet	200 (340)	200 (340)	200 (340)	324 (550)	365 (620)
Noise Level dB(A) (Cig/Htg): Hi	36/36	37/37	40/40	43/44	49/48
Medium	32/32	33/33	36/36	37/37	42/42
Low	29/29	29/29	30/31	33/33	37/37
Quiet	25/25	25/25	25/25	31/31	33/33
Running Current Rated (A): Cooling	0.13	0.15	0.19	0.32	0.53
Heating	0.13	0.15	0.19	0.32	0.53
Power Use Rated (w): Cooling	15	17	22	41	69
Heating	15	17	22	41	69
Fan Speeds Stage	4+auto	4+auto	4+auto	4+auto	4+auto
Air Direction: Horizontal	Manual	Manual	Manual	Manual	Manual
Vertical	Auto	Auto	Auto	Auto	Auto
Primary Air Filter	Washable	Washable	Washable	Washable	Washable
Ion Deodorizing Filter	Disposable	Disposable	Disposable	Disposable	Disposable
Apple-Catechin Filter	Disposable	Disposable	Disposable	Disposable	Disposable
Connection Method	Flare	Flare	Flare	Flare	Flare
Conn. Pipe Diameter Inch	suc 3/8 dis 1/4	suc 3/8 dis 1/4	suc 3/8 dis 1/4	suc 1/2 dis 1/4	suc 5/8 dis 1/4
Net Weight lbs. (kg)	18 (8)	18 (8)	18 (8)	31 (14)	31 (14)
Dimensions: Height Inch (mm)	11-1/16 (280)	11-1/16 (280)	11-1/16 (280)	12-5/8 (320)	12-5/8 (320)
Width Inch (mm)	31-1/16 (790)	31-1/16 (790)	31-1/16 (790)	39-1/4 (998)	39-1/4 (998)
Depth Inch (mm)	8 (203)	8 (203)	8 (203)	9 (228)	9 (228)
Refrigerant	R410A	R410A	R410A	R410A	R410A

Built In Filtration



Long-life+ Ion Deodorization Filter

The filter deodorizes by powerfully decomposing absorbed odors using the oxidizing and reducing effects of ions generated by the ultra-fine-particle ceramic.



Apple-Catechin Filter

Dust, mold spores and microorganisms are absorbed onto the filter by static electricity and growth is inhibited and deactivated.

Easy Maintenance

Front panel is easily removed for cleaning.



Standard Features

- Apple Catechin Filter
- Ion Deodorizing Filter
- Sleep Timer
- 24-Hour Timer
- Dry Mode
- Auto Louver: Up/ Down
- Long Piping Length (165'+)
- Auto Mode
- Minimum Heat Mode
- Quiet Mode
- Auto Restart/Reset
- Auto Changeover
- Power Diffuser*

+ The filter can be used for approximately 3 years if it is washed with water when dirty to restore its surface action.

*Feature of models ASU18, 24RLF only.



Compact Cassettes 9, 12, and 18,000 BTUs

AUU9RLF, AUU12RLF, AUU18RLF



Easy Installation

Fits into a standard ceiling tile*. Compact cassette and slim duct models can be networked.

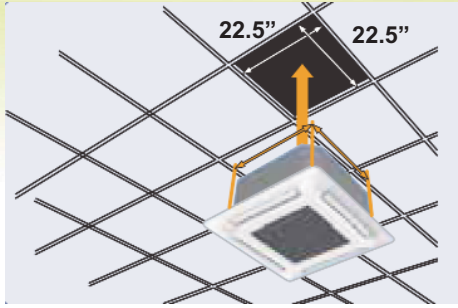

*Dimensions of outer grille are 27-9/16" x 27-9/16" and may overlap adjacent tiles.

2-Stage Turbo Fan

Air distribution is evenly spread across the heat exchanger by the new 2 stage turbo fan which produces two separate airflow streams.

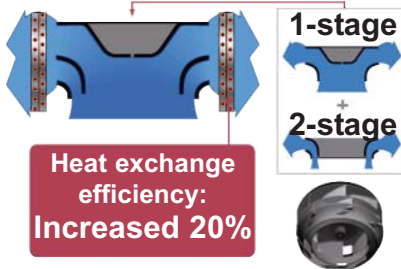

Standard Features

- Sleep Timer
- Dry Mode
- Auto Louver: Up/ Down
- Quiet Mode
- Auto Restart/Reset
- Auto Changeover
- Long Piping Length (165'+)
- Remote Temperature Sensor
- High Ceiling Mode
- Condensate Pump
- 2-Stage Turbo Fan
- Fresh Air Intake**



	AUU9RLF Heat Pump	AUU12RLF Heat Pump	AUU18RLF Heat Pump
Nominal Cooling BTU/h	9,000	12,000	18,000
Nominal Heating BTU/h	10,200	13,500	20,000
Voltage/Frequency/Phase	208-230/60/1	208-230/60/1	208-230/60/1
Air Circ. C.F.M. (m ³ /h): Hi	318 (540) Clg or Htg	359 (610) Clg or Htg	441 (750) Clg 471 (800) Htg
Medium	288 (490) Clg or Htg	312 (530) Clg or Htg	359 (610) Clg 418 (710) Htg
Low	259 (440) Clg or Htg	277 (470) Clg or Htg	306 (520) Clg 353 (600) Htg
Quiet	230 (390) Clg or Htg	241 (410) Clg or Htg	241 (410) Clg 265 (450) Htg
Noise Level dB(A) Clg/Htg: Hi	33/34	37/37	42/44
Medium	31/32	33/33	37/40
Low	29/29	31/31	33/37
Quiet	27/27	28/28	29/30
Running Current Rated (A): Cooling	0.15	0.19	0.30
Heating	0.15	0.19	0.30
Power Use Rated/Max (W): Clg	18	23	39
Heating	18	23	39
Fan Speeds Stage	4+auto	4+auto	4+auto
Air Direction: Vertical	Automatic	Automatic	Automatic
Air Filter	Washable	Washable	Washable
Front Grille	UTG-CCGF*	UTG-CCGF*	UTG-CCGF*
Connection Method	Flare	Flare	Flare
Conn. Pipe Diameter Inch	suc 3/8 dis 1/4	suc 3/8 dis 1/4	suc 1/2 dis 1/4
Net Weight lbs. (kg)	33 (15)	33 (15)	33 (15)
Chassis Dim: Height Inch (mm)	9-11/16 (245)	9-11/16 (245)	9-11/16 (245)
Width Inch (mm)	22-7/16 (570)	22-7/16 (570)	22-7/16 (570)
Depth Inch (mm)	22-7/16 (570)	22-7/16 (570)	22-7/16 (570)
Grille Dim: Height Inch (mm)	1-15/16 (49)	1-15/16 (49)	1-15/16 (49)
Width Inch (mm)	27-9/16 (700)	27-9/16 (700)	27-9/16 (700)
Depth Inch (mm)	27-9/16 (700)	27-9/16 (700)	27-9/16 (700)
Refrigerant	R410A	R410A	R410A

**Requires Fujitsu's Optional Fresh Air Kit part #UTZ-VXAA. Allows for a 4-inch flex duct connection and a field supplied duct booster capable of 60 CFM at a .2" W.C. or 90 CFM at .4" W.C. For fan curve, see installation manual.

* Compact Cassette Grille UTG-CCGF sold separately. Must order one with each compact cassette.



Fresh Air Kit** UTZ-VXAA

mixes room air then passes through the heat exchanger.



Slim Duct 9, 12, 18 and 24,000 BTUs

ARU9RLF, ARU12RLF, ARU18RLF, ARU24RLF



ARU9, 12RLF



ARU18, 24RLF

	ARU9RLF Heat Pump	ARU12RLF Heat Pump	ARU18RLF Heat Pump	ARU24RLF Heat Pump
Nominal Cooling BTU/h	9,000	12,000	18,000	24,000
Nominal Heating BTU/h	10,200	13,500	20,000	27,000
Low Temp. Heating 17°F BTU/h	TBA	TBA	TBA	TBA
Voltage/Frequency/Phase	208-230/60/1	208-230/60/1	208-230/60/1	208-230/60/1
Recommended Static Pressure In. W. C.	0 ~ 0.36	0 ~ 0.36	0 ~ 0.36	0 ~ 0.20
Air Circ. C.F.M. (m ³ /h) Clg/Htg: Hi	353 (600)	383 (650)	554 (940)	783 (1,330)
Medium	324 (550)	353 (600)	518 (880)	730 (1,240)
Low	294 (500)	324 (550)	483 (820)	648 (1,100)
Quiet	265 (450)	283 (480)	442 (750)	607 (1,030)
Noise Level dB(A) (Clg/Htg): Hi	28/28	29/29	32/33	33/35
Medium	27/27	28/28	31/32	32/34
Low	26/26	27/27	30/31	30/32
Quiet	25/24	26/25	29/29	29/29
Running Current Rated (A): Cooling	0.30	0.35	0.44	0.66
Heating	0.30	0.35	0.44	0.66
Power Use Rated (W): Cooling	49	58	73	111
Heating	49	58	73	111
Fan Speeds Stage	4 + Auto	4 + Auto	4 + Auto	4 + Auto
Air Filter	Washable	Washable	Washable	Washable
Connection Method	Flare	Flare	Flare	Flare
Conn. Pipe Diameter Inch	suc 3/8 dis 1/4	suc 3/8 dis 1/4	suc 1/2 dis 1/4	suc 5/8 dis 1/4
Net Weight lbs. (kg)	41 (19)	41 (19)	50 (23)	59 (27)
Dimensions: Height Inch (mm)	7-25/32 (198)	7-25/32 (198)	7-25/32 (198)	7-25/32 (198)
Width Inch (mm)	27-9/16 (700)	27-9/16 (700)	35-7/16 (900)	43-5/16 (1,100)
Depth Inch (mm)	24-13/32 (620)	24-13/32 (620)	24-13/32 (620)	24-13/32 (620)
Supply Duct Flange	5-15/16 (151)	5-15/16 (151)	5-15/16 (151)	5-15/16 (151)
Dimensions: Height Inch (mm)	25-19/32 (650)	25-19/32 (650)	33-15/32 (850)	41-11/32 (1,050)
Width Inch (mm)	3/4 (19)	3/4 (19)	3/4 (19)	3/4 (19)
Depth Inch (mm)	3/4 (19)	3/4 (19)	3/4 (19)	3/4 (19)
Return Duct Flange	6-27/32 (174)	6-27/32 (174)	6-27/32 (174)	6-27/32 (174)
Dimensions: Height Inch (mm)	22-19/32 (574)	22-19/32 (574)	30-15/32 (774)	38-11/32 (974)
Width Inch (mm)	3/4 (19) (Flat)	3/4 (19) (Flat)	3/4 (19) (Flat)	3/4 (19) (Flat)
Depth Inch (mm)	3/4 (19) (Flat)	3/4 (19) (Flat)	3/4 (19) (Flat)	3/4 (19) (Flat)
Refrigerant	R410A	R410A	R410A	R410A

Slim Duct

Adaptable when ceiling cavity is small and there is no slope for drain.

Traditional

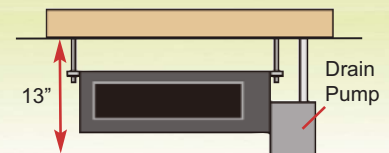

Slim Duct



Return Air-intake

Air intake direction can be selected to match the installation site.

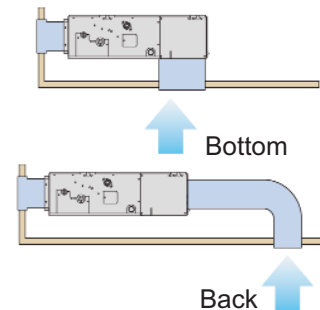

Standard Features

- Dry Mode
- Weekly Timer
- Sleep Timer*
- 24-Hour Timer*
- Minimum Heat Mode*
- Auto Mode
- Quiet Mode
- Auto Restart/Reset
- Auto Changeover
- Long Piping Length (165'+)
- Condensate Pump
- Fresh Air Intake

*Available only with optional wireless remote control.



Branch Boxes

UTP-PU03A, UTP-PU03B



UTP-PU03A



UTP-PU03B

	UTP-PU03A Primary	UTP-PU03B Secondary
Connectable Indoor Unit	1 ~ 3	1 ~ 3
Max. Combination <i>BTU/h</i>	62,000 Nom.*	62,000 Nom.*
Min. Combination <i>BTU/h</i>	7,000 Nom.*	7,000 Nom.*
Clg. Operating Range °F(°C)	25-115 (-5-46)	25-115 (-5-46)
Htg. Operating Range °F(°C)	5-75 (-15-24)	5-75 (-15-24)
%RH	80 or less	80 or less
Voltage/Frequency/Phase	208-230/60/1	208-230/60/1
Maximum Current Ampacity (A)	15	15
Running Current <i>Rated</i> (A): Cooling	0.050	0.050
Heating	0.050	0.050
Power Use <i>Rated</i> (W): Cooling	10	10
Heating	10	10

*So long as the total system nominal capacity is between 39,000 and 62,000 BTUs.

Dimensions: Gross (Flare to Flare):

Height x Width x Depth *Inch*

Height x Width x Depth *mm*

Dimensions: Net (Metal Box Only):

Height x Width x Depth *Inch*

Height x Width x Depth *mm*

Net Weight *lbs. (kg)*

Conn. Pipe Diameter - Main *Inch*

Conn. Pipe Diameter - Branch *Inch*

Connection Method

Connection Adapter Included *Inch*

	UTP-PU03A Primary	UTP-PU03B Secondary
Height x Width x Depth <i>Inch</i>	10 x 36-5/8 x 17-1/8	10 x 36-5/8 x 17-1/8
Height x Width x Depth <i>mm</i>	255 x 929 x 434	255 x 929 x 434
Height x Width x Depth <i>Inch</i>	7-5/8 x 17 x 14-5/8	7-5/8 x 17 x 14-5/8
Height x Width x Depth <i>mm</i>	195 x 433 x 370	195 x 433 x 370
Net Weight <i>lbs. (kg)</i>	20 (9)	20 (9)
Conn. Pipe Diameter - Main <i>Inch</i>	(3/8 Liq. x 5/8 Suc.)	(3/8 Liq. x 5/8 Suc.)
Conn. Pipe Diameter - Branch <i>Inch</i>	(1/4 Liq. x 1/2 Suc.) 3 pair	(1/4 Liq. x 1/2 Suc.) 3 pair
Connection Method	Flare	Flare
Connection Adapter Included <i>Inch</i>	(1/2MF x 3/8FF) x 3 (1/2MF x 5/8FF) x 3	(1/2MF x 3/8FF) x 3 (1/2MF x 5/8FF) x 3
	No adapter needed for 18k BTU	No adapter needed for 18k BTU

Warning: Branch boxes are not weather tight enclosures and cannot be mounted outdoors or in damp environments exceeding 80% relative humidity.

Clearances

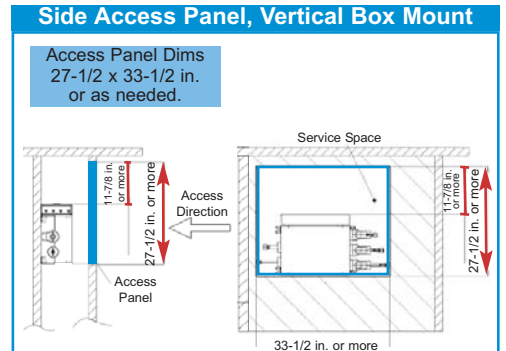
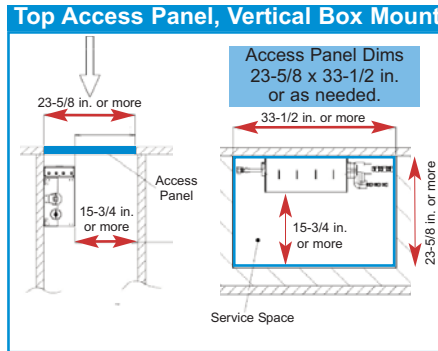
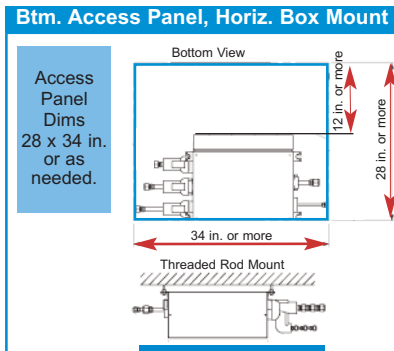

Dimensions *In (mm)*

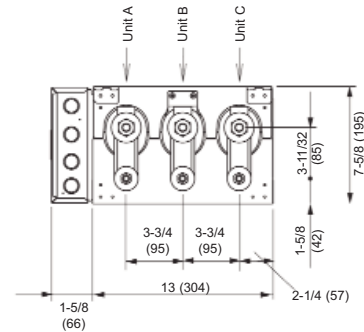
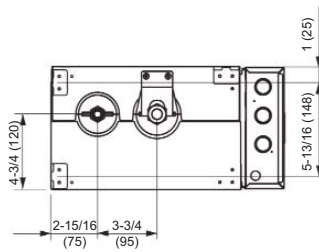
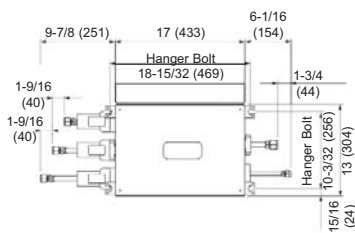

Allowed Branch Box Mounting Direction

Threaded Rod Mount

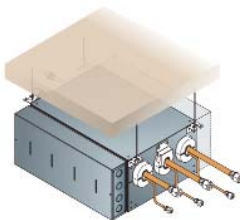

By reversing the electrical box position you can orient the inlet and outlet pipes into a left hand or right hand configuration.

Horizontal Wall Mount

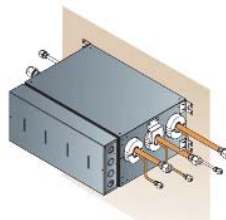

By reversing the electrical box position you can orient the inlet and outlet pipes into a left hand or right hand configuration.

Vertical Wall Mount

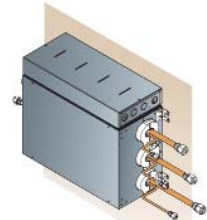

You cannot reverse the electrical box position when mounting the branch box vertically.

Allowable Combinations

156 Combinations Based on BTU (3,266 Combo's Based on Indoor Type and BTU)



ASU7RLF
ASU9RLF
ASU12RLF
ASU18RLF
ASU24RLF



ARU9RLF
ARU12RLF
ARU18RLF
ARU24RLF



AUU9RLF*
AUU12RLF*
AUU18RLF*



AOU48RLXFZ

BTU Capacity 7,000 9,000 12,000 18,000 24,000

Indoor Units	7,000	9,000	12,000	18,000	24,000	Total
2 INDOOR UNITS	18 24					42
	24 24					48
3 INDOOR UNITS	7 9 24					40
	7 12 24					43
	7 18 18					43
	7 18 24					49
	7 24 24					55
	9 9 24					42
	9 12 18					39
	9 12 24					45
	9 18 18					45
	9 18 24					51
4 INDOOR UNITS	9 24 24					57
	12 12 18					42
	12 12 24					48
	12 18 18					48
	12 18 24					54
	12 24 24					60
	18 18 18					54
	18 18 24					60
	7 7 7 18					39
	7 7 7 24					45
5 INDOOR UNITS	7 7 9 18					41
	7 7 9 24					47
	7 7 12 18					44
	7 7 12 24					50
	7 7 18 18					50
	7 7 18 24					56
	7 7 24 24					62
	7 9 9 18					43
	7 9 9 24					49
	7 9 12 12					40
6 INDOOR UNITS	7 9 12 18					46
	7 9 12 24					52
	7 9 18 18					52
	7 9 18 24					58
	7 9 24 24					64
	7 12 12 12					43
	7 12 12 18					49
	7 12 12 24					55
	7 12 18 18					59
	7 12 18 24					65
7 INDOOR UNITS	7 7 7 7 18					49
	7 7 7 7 24					55
	7 7 7 9 18					53
	7 7 7 9 24					59
	7 7 7 12 18					54
	7 7 7 12 24					60
	7 7 7 18 18					60
	7 7 7 18 24					66
	7 7 7 24 24					72
	7 9 9 9 18					51
8 INDOOR UNITS	7 9 9 9 24					57
	7 9 12 12 12					47
	7 9 12 12 18					53
	7 9 12 12 24					59
	7 9 18 18 18					65
	7 9 18 18 24					71
	7 9 24 24 24					77
	7 12 12 12 12					48
	7 12 12 12 18					54
	7 12 12 12 24					60

Allowed "Connectable = Capacity" combinations between 100 and 130%

* Compact Cassette Grille UTG-CCGF sold separately. Must order one with each compact cassette.

Separation Tube Assembly Kit

UTP-SX248A

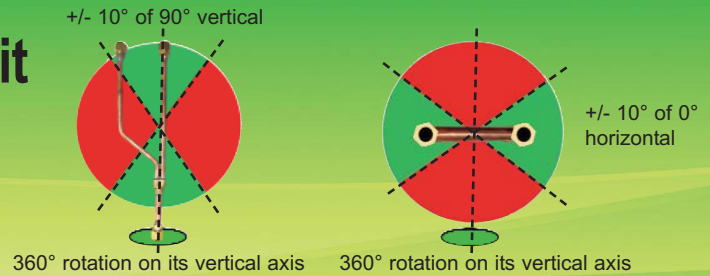

Size	Liquid Inch	3/8 x 3/8 x 3/8
	Suction Inch	5/8 x 5/8 x 5/8

Optional Accessories

Central Remote Control #UTY-DMMUM

This remote controls up to 8 individual indoor units on a Hybrid Flex Inverter (HFI) system. Set temperatures on timers to best meet individuals' needs. The sleek design includes a large backlit LCD and 4-way navigation pad. Remote connects in daisy chain to branch boxes.



Wired Remote Control for Wall Mounts #UTY-RNNUM

The wired remote controller with its unique lock function and sleek design provides full feature access to property managers, building owners, and facility maintenance, as well as providing basic comfort features to tenants, employees, and teachers. Requires interface kit UTY-XCBXZ1.



Simple Remote Control #UTY-RSNUM

Suitable when only basic operations are required for hotels, offices and other places where there is frequent arrival and departure of occupants. To be used with all HFI indoor models.



Receiver Unit #UTY-LRHUM

Includes a wireless remote control. For use on slim duct Halcyon HFI indoor units



External Switch #UTY-TEKX

Allows system to be operated by third party control such as key card switch or remote sensor. External switch controller can provide access to On/Off, Temperature, Fan speed, and Operation mode. To be used with all HFI indoor models.



Wireless Remote Controller #UTY-LNHUM

For spaces where there is just no place to mount the wired remote. For use only with HFI compact casettes.



Field Supplied Filters Used With Slim Duct Units

Slim Duct Units require field supplied filters. They can be installed at the unit or for more convenient servicing, in filter grilles. The chart to the right provides guidelines for determining filter sizes.

The chart includes CFM, external static pressure capability and a typical filter size for each model. Filters are sized to keep velocities and static pressure loss low. This will insure sufficient static pressure is available for ductwork, fittings and supply and return grilles. Alternative filter sizes with equivalent face areas can be used. After deducting filter loss, available static pressure values are shown.

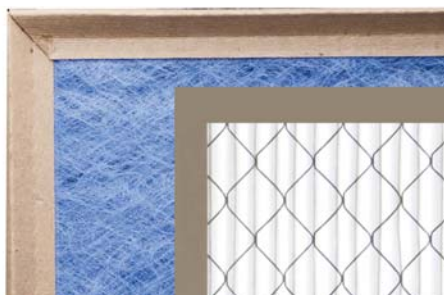

A fiberglass filter is shown in blue to the left. A MERV pleated filter is shown in white.

	ARU 9RLF	ARU 12RLF	ARU 18RLF	ARU 24RLF
CFM	353	353	547	806
Typical Filter Size	12 x 20	12 x 20	14 x 25	18 x 30
Velocity, FPM	212	212	225	215
Unit External SP, in. W.C.	0.36	0.36	0.36	0.20
1" Fiberglass Filter				
SP Loss, in. W.C.	0.04	0.04	0.04	0.04
Available Static Pressure	0.32	0.32	0.32	0.16
1" MERV 8 Pleated Filter				
SP Loss, in. W.C.	0.12	0.12	0.14	0.13
Available Static Pressure	0.24	0.24	0.22	0.07
2" MERV 8 Pleated Filter				
SP Loss, in. W.C.	0.07	0.07	0.08	0.07
Available Static Pressure	0.29	0.29	0.28	0.13

Wiring

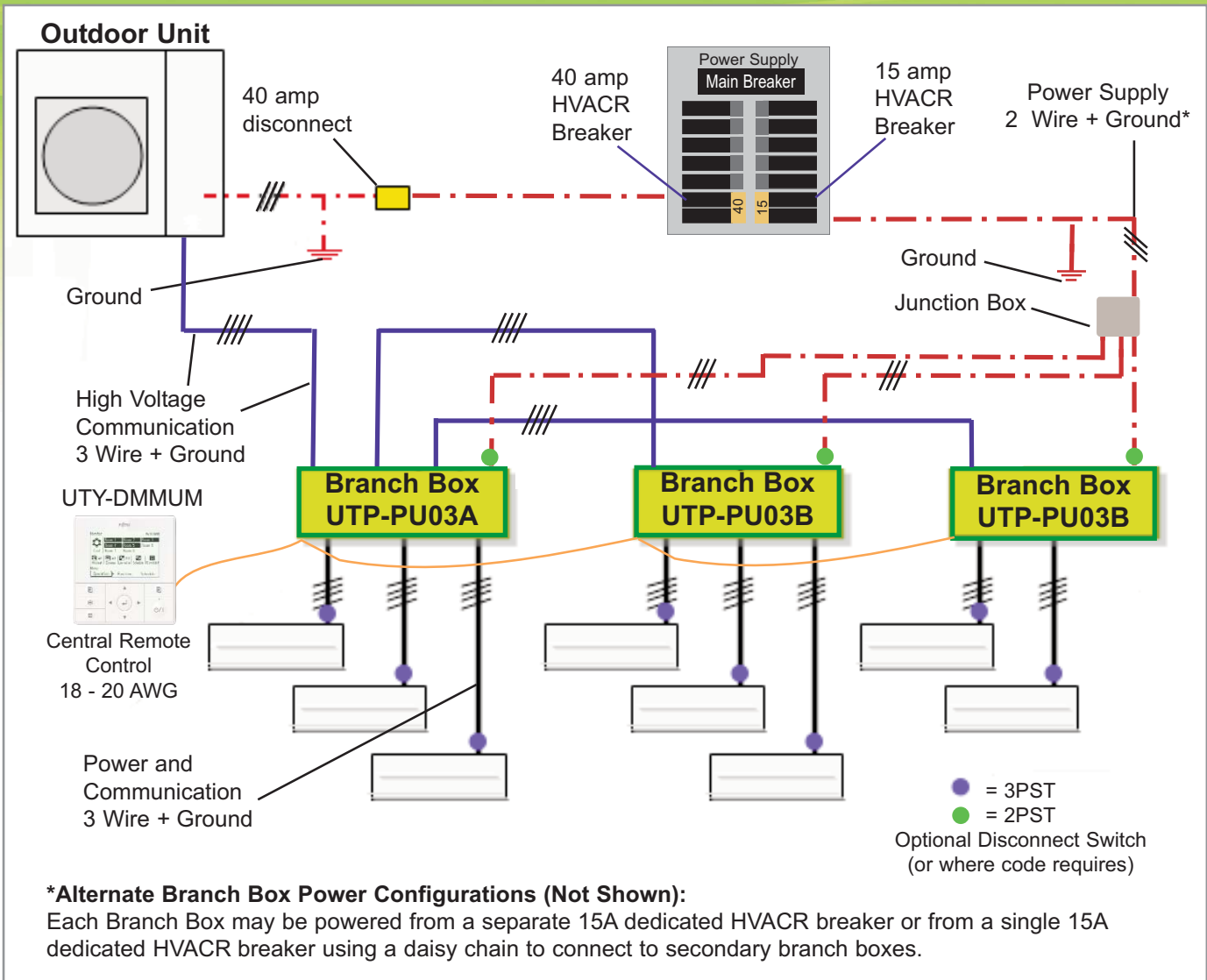

Branch Box Terminal Connections

Miswiring Detection

Errors Detected For...

- Miswired terminals
- Incorrect indoor unit
- Less than 2 or more than 8 indoor units
- Less than 39,000 or more than 62,000 BTUs

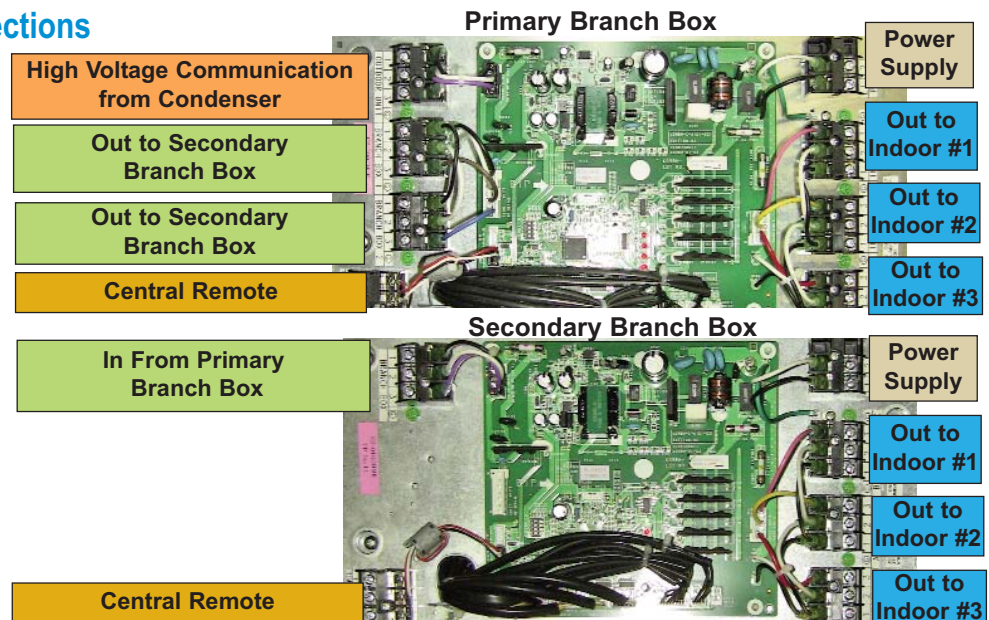

Piping

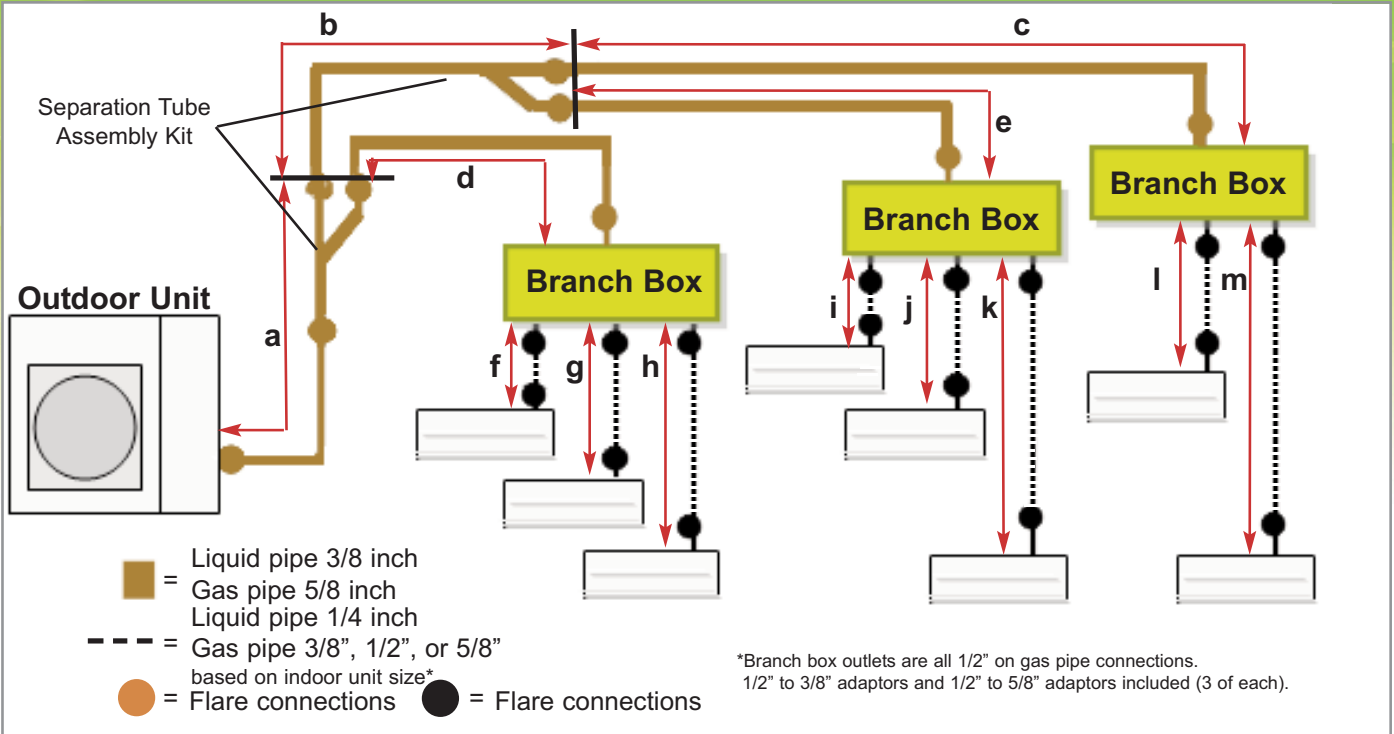

		Liquid pipe	Adaptor	Gas pipe
Branch Box to Indoor	7,000 BTU	1/4 inch	included	3/8 inch
	9,000 BTU		included	
	12,000 BTU		included	1/2 inch
	18,000 BTU		n/a	
	24,000 BTU		included	
Calculate Refrigerant Charge	Pipe Diameter	Location		Additional Refrig.
	3/8"	Outdoor to Branch Box		0.624 oz./ft. or 58g/meter
	1/4"	Branch Box to Indoor Unit		0.224 oz./ft. or 21g/meter
Factory Charge 7.6 lb (3.45 kg) Unit pre-charged to 0 feet (Total length of 3/8" liquid line × 0.624 oz./ft. or 58g/meter) + (Total length of 1/4" liquid line × 0.224 oz./ft. or 21g/meter) (a+b+c+d+e) × 0.624 oz./ft. or 58g/meter + (f+g+h+i+j+k+l+m) × 0.224 oz./ft. or 21g/meter = additional refrigerant				

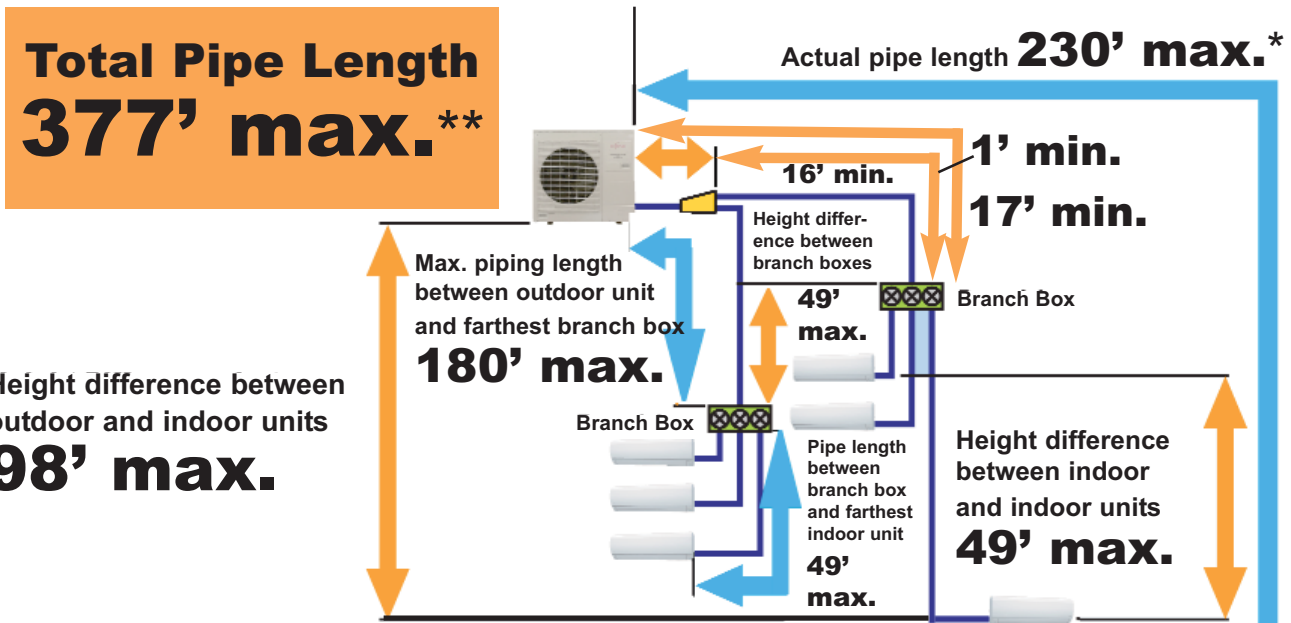

* Distance between outdoor unit & farthest indoor unit.
** Total liquid pipe or total gas pipe.

Examples

Residential 1-story home

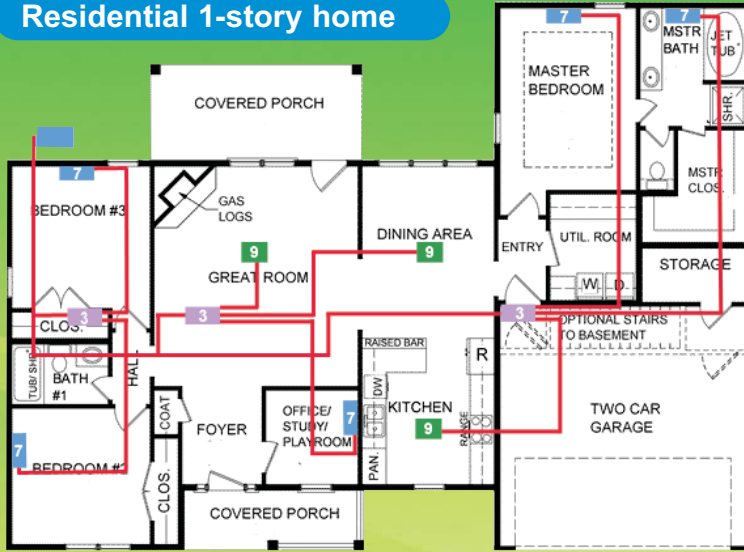

Residential 2-story home

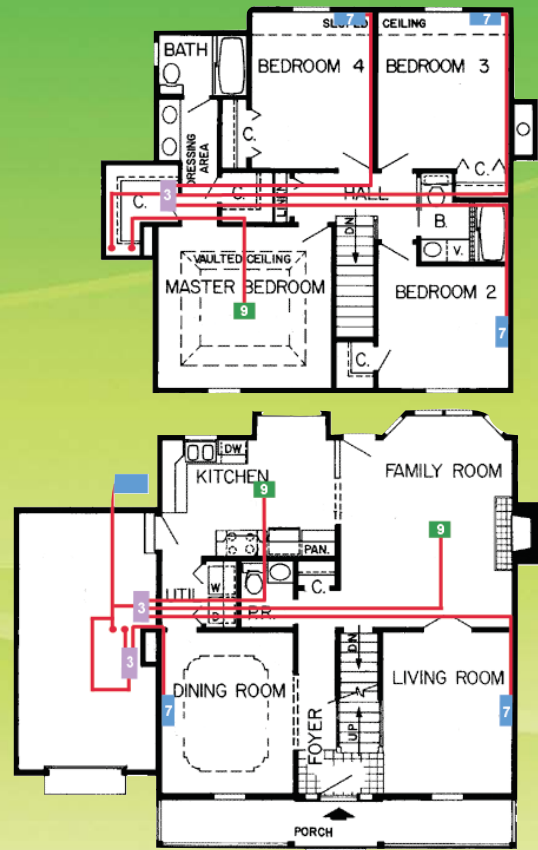

Church/School

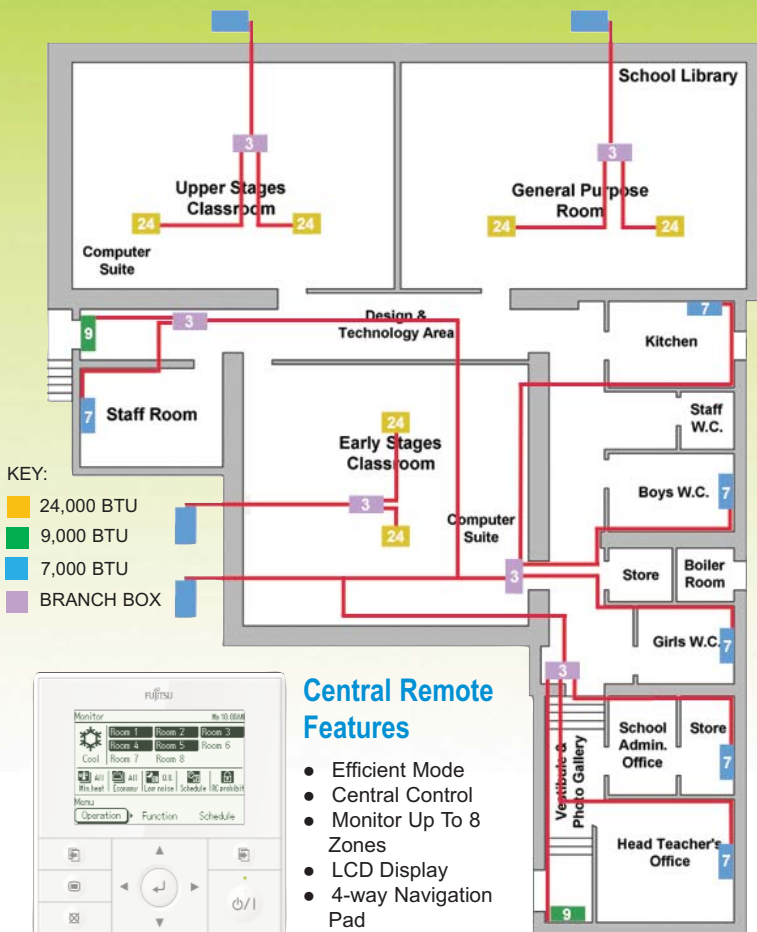

Fujitsu General America, Inc.
 353 Route 46 West
 Fairfield, NJ 07004
 Toll Free: (888) 888-3424
 Local: (973) 575-0380
 Fax: (973) 836-0447
 Email: hvac@fujitsugeneral.com
 www.fujitsugeneral.com

A subsidiary of
 Fujitsu General Limited

